

# American Broadband

## Connect Your Cable-Modem

- What's In the Box:**
- Modem & Power Cord
  - Ethernet cord (yellow)
  - Coaxial cord (black)



### Steps To Take:

**1**

- **Connect** coaxial cable to wall and to your modem.

**2**

- **Connect** the Ethernet cord to your Modem and your Computer.\*  
If you have a Router, connect it to the WAN port on Router.\*\*

**3**

- **Connect** the Power Plug to your Modem and to an electrical wall-outlet. This automatically **Powers ON** your Cable Modem.
- **Check that the Power, Receive, Send, and Online front panel LEDs on your Modem light up in sequential order.**
- **All four lights** should transition to solid green or blue.

**4**

- **Power ON** your Computer/Router and log in.

\* It is not recommended to connect directly to a PC or Laptop other than for troubleshooting.

\*\*A Home Router • Gateway • Firewall is highly recommended for normal use.

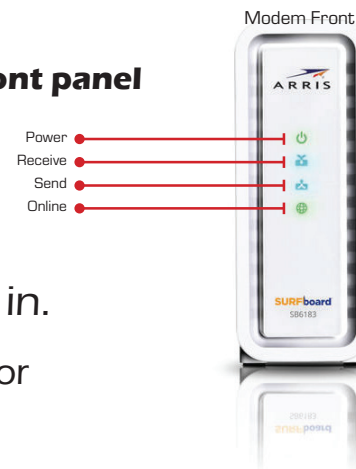
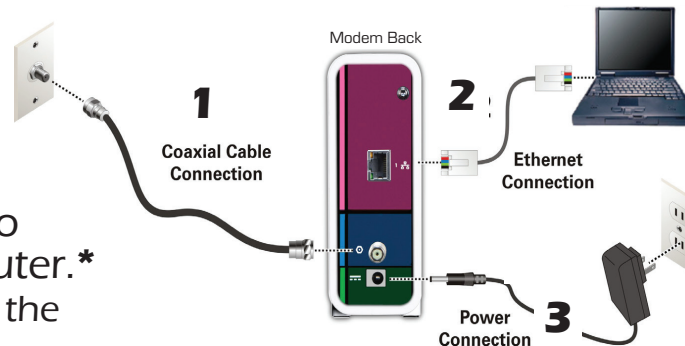

**If you have problems, questions or concerns  
please contact us:**

American Broadband

**Your Solution  
For SPEED**

**1-888-262-2661**

**ABBNebraska.com**